



Speed Sensor HSS 220

2 channel

Screw-in thread M18

Direct detection of direction of rotation

Description:

The contact-free speed sensors of the HSS 220 series detect the movement of ferromagnetic structures, such as gear wheels, gear rims or perforated discs, using the changes in magnetic flux.

So each sensor has two Hall elements and the differential between the two signals is detected, evaluated and then converted into an output signal suitable for processing.

For integration into standard controls, standard output signals are available.

Due to their extremely compact design, the robust housing and protection class IP 67, the instruments can be used in almost any application and any mounting position.

The main fields of application are detection of speed and rotation direction on gear wheels with a small module and high resolution, especially in rail vehicles and mobile machines.

Technical data:

Input data	
Frequency range	0.1 .. 20,000 Hz
Installation depth	0 .. 48 mm adjustable
Max. pressure on sensing surface	10 bar, static
Mechanical connection	Screw-in thread M18x1
Tightening torque, recommended	Max. 12 Nm
Type of installation	Dependent on direction
Housing material	X12CrNiS18 8
Output data	
Output signal	2 NPN frequency outputs Signal level: HIGH: $\geq +U_b - 2 \text{ V}$ / LOW: $\leq 2 \text{ V}$ Max. switching current: $\leq 50 \text{ mA}$ (36 V, 125 °C, 50 % duty cycle) $\leq 500 \text{ mA}$ (24 V, 25 °C, 50 % duty cycle) 1 NPN frequency output + 1 NPN dir. of rotation output Signal level: HIGH: $\geq +U_b - 2 \text{ V}$ / LOW: $\leq 2 \text{ V}$ Max. switching current: $\leq 50 \text{ mA}$ (36 V, 125 °C, 50 % duty cycle) $\leq 500 \text{ mA}$ (24 V, 25 °C, 50 % duty cycle)
Environmental conditions	
Operating temperature range	-40 .. +125 °C
Media resistance of housing	Saltwater, various hydraulic oils
CE mark	EN 61000-4-2 / 3 / 4 / 6
Vibration resistance acc. to EN 60068-2-6	15 g / 3 .. 2,000 Hz
Shock resistance acc. to EN 60068-2-27	30 g, 11 ms, 3x in each direction
Protection class acc. to IEC 60529	IP 67 (when an IP 67 mating connector is used)
Other data	
Electrical connection	Male M12x1, 4 pole
Supply voltage	8 .. 32 V DC
Residual ripple of supply voltage	$\leq 5 \%$
Current consumption	< 33 mA at 24 V, both outputs LOW < 23 mA at 24 V, both outputs HIGH
Life expectancy	1,100,000 h (MTTF) / 2,200,000 h (MTTF _d)
Weight	~ 80 g

Note: Reverse polarity protection of the supply voltage and load short circuit protection are provided.

Switching/installation distance:

Module 1	0.2 .. 1.3 mm
Module 1.25	0.2 .. 1.8 mm
Module 1.5	0.2 .. 2.0 mm
Module 2	0.2 .. 2.5 mm
Module 2.5	0.2 .. 3.5 mm

Pin connections:

M12x1, 4 pole

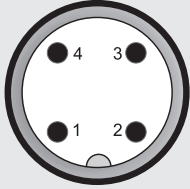

Pin	HSS 220-2	HSS 220-3
1	+U _B	+U _B
2	Frequency 2 (B)	Direction of rotation
3	0 V	0 V
4	Frequency 1 (A)	Frequency

Direction of rotation:

Marking on housing at 90° to rotational direction, gear rotation clockwise: channel A leading, channel B following or direction of rotation signal (right HIGH / left LOW)

Adjustment angle for other modules:

It is possible to achieve a 90° phase shift of the two frequency signals by turning the sensor accordingly.

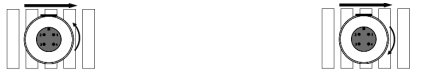

-12°	Module 1	
- 9°	Module 1.25	
- 7°	Module 1.5	
- 3°	Module 1.75	
± 0°	Module 2	± 0°
	Module 2.25	+ 4°
	Module 2.5	+ 8°
	Module 2.75	+13°
	Module 3	+17°

Dimensions:

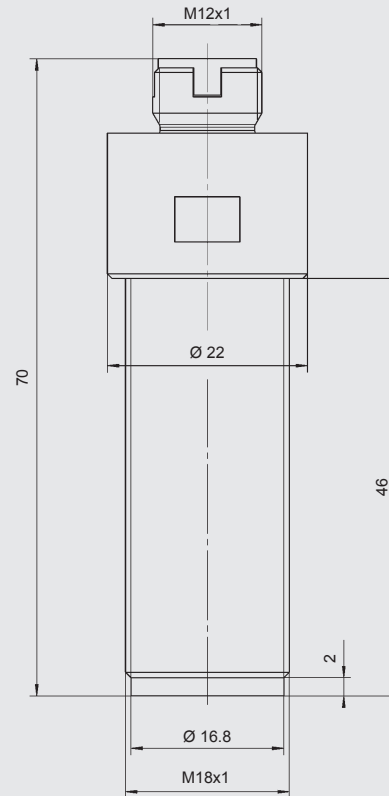

Model code:

HSS 2 2 0 - X - 046 - 000

Signal technology

- 2 = outputs 1 and 2: frequency (90° / 270° phase shift for module "2")
- 3 = output 1: frequency
output 2: direction of rotation

Installation depth

046 = 46 mm max.

Modification number

000 = standard

Note:

The information in this brochure relates to the operating conditions and applications described. For applications or operating conditions not described, please contact the relevant technical department.

Subject to technical modifications.

HYDAC ELECTRONIC GMBH
Hauptstr. 27, 66128 Saarbrücken
Germany
Telephone +49 (0)6897 509-01
Fax +49 (0)6897 509-1726
e-mail: electronic@hydac.com
Internet: www.hydac.com